

Future Room

Entdecken Sie die Zukunft
Ihres Unternehmens

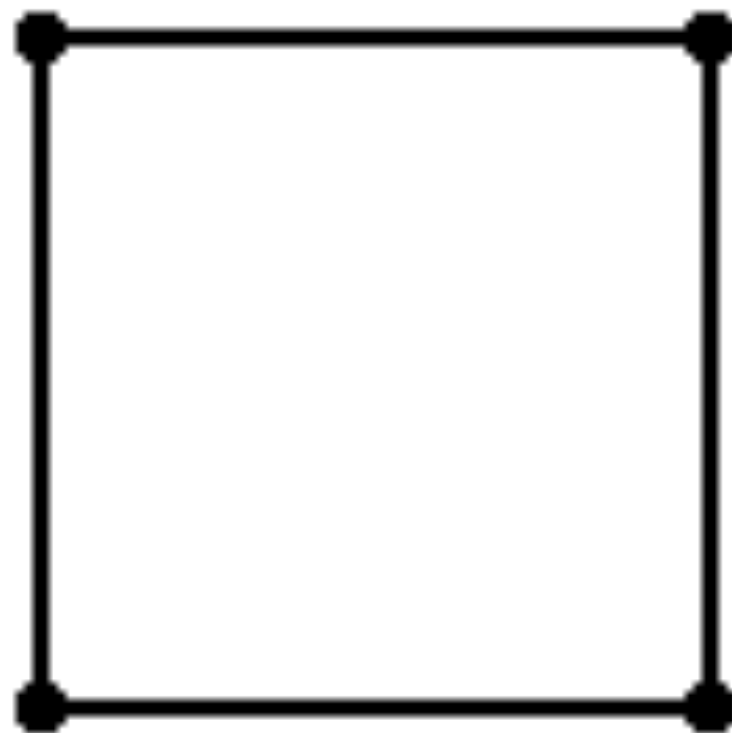





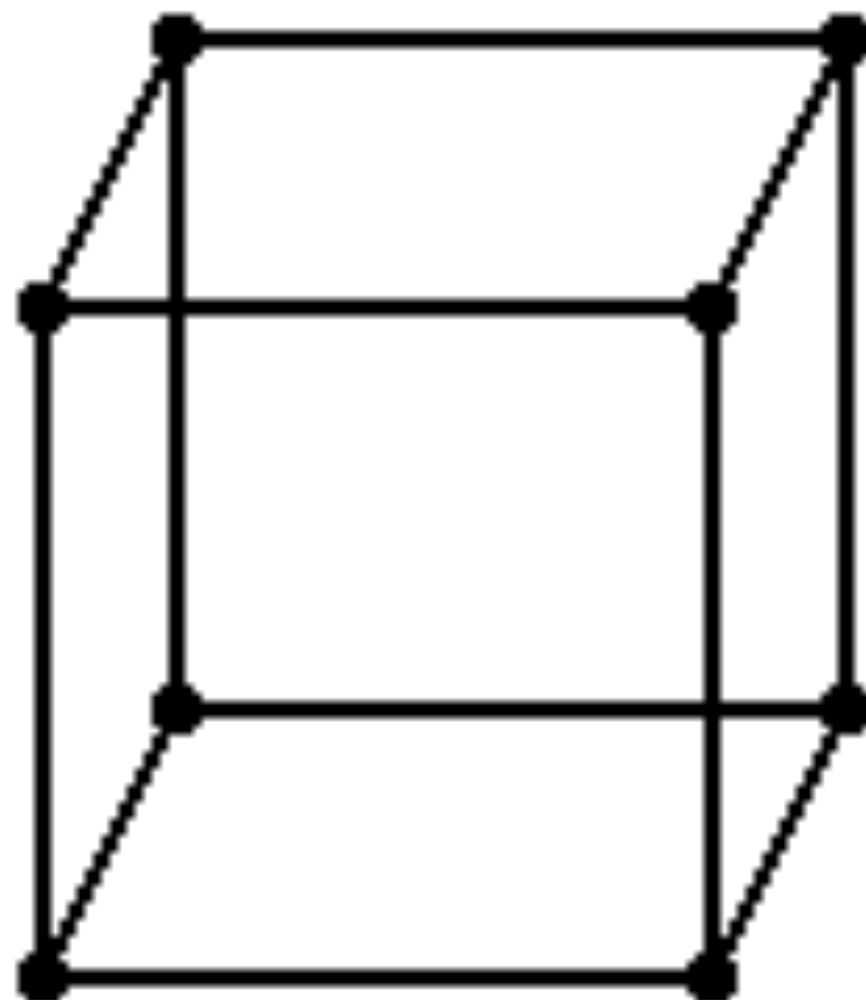
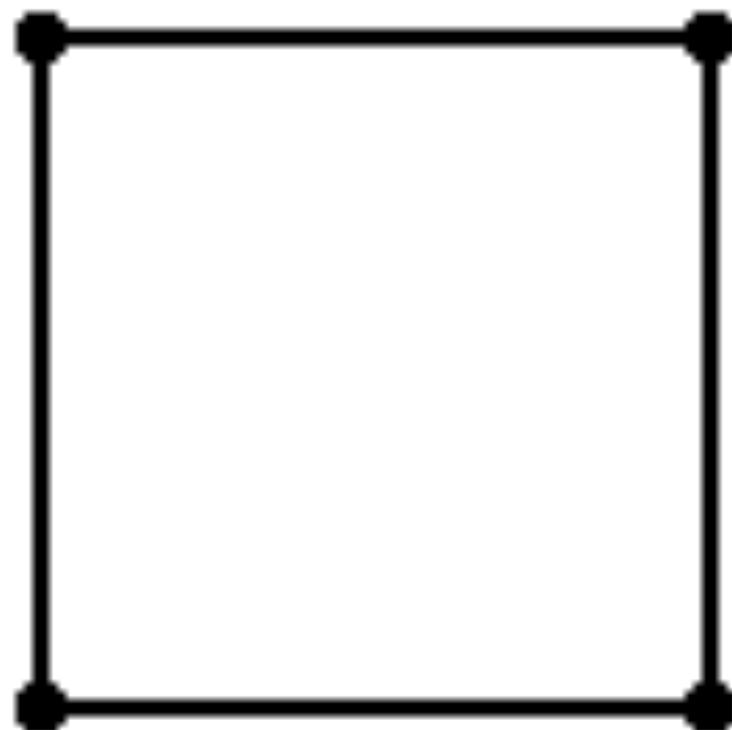

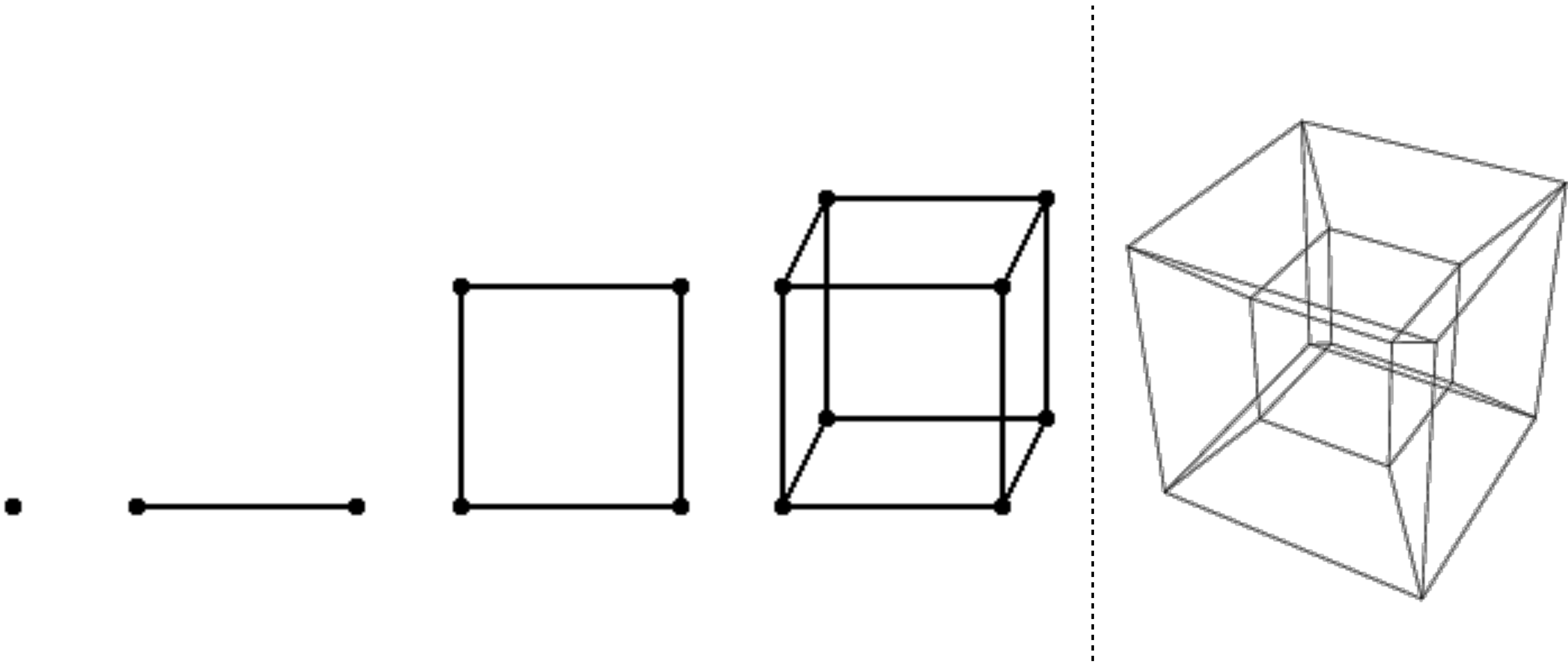

Hypercube

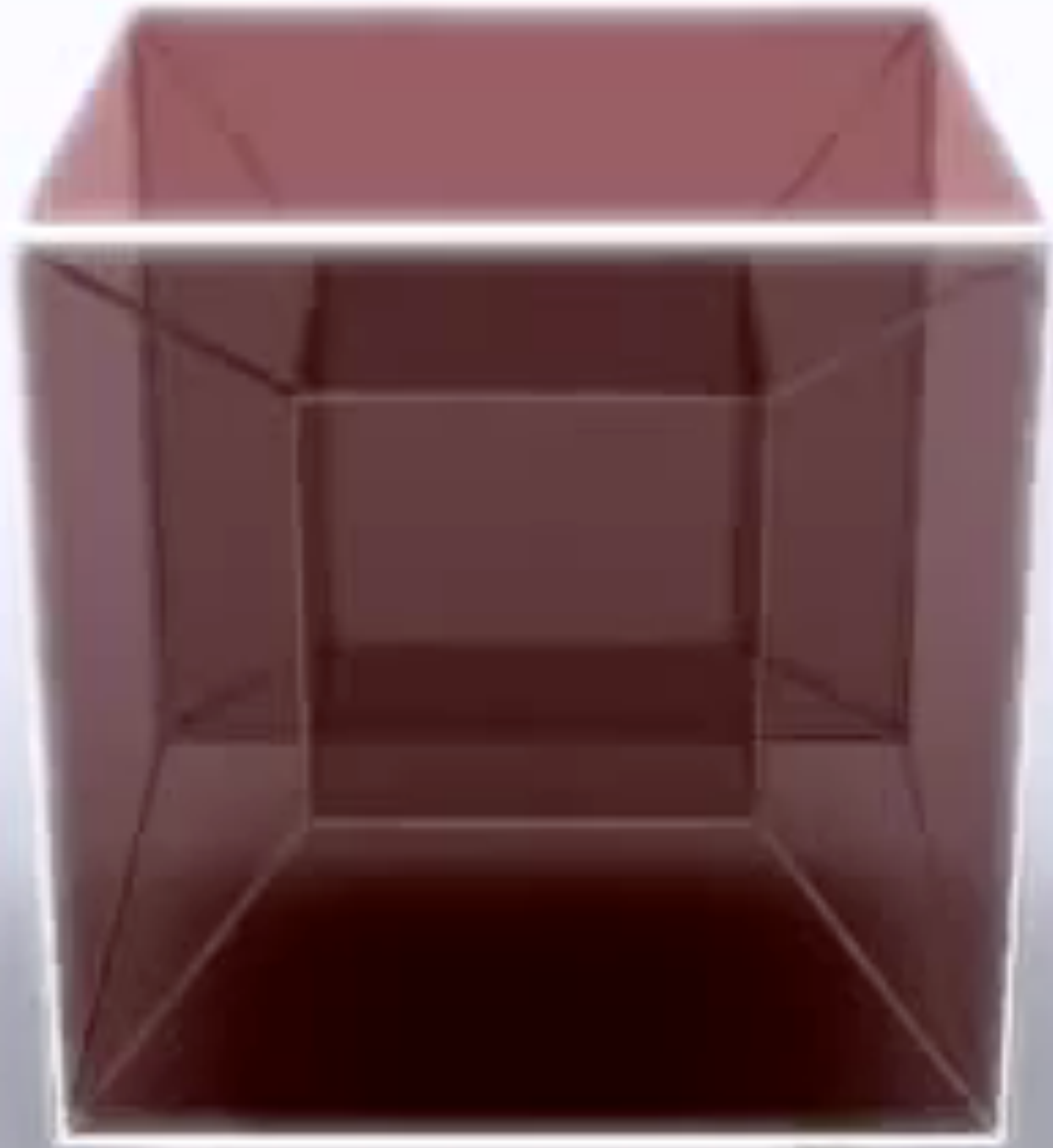

Hypercube

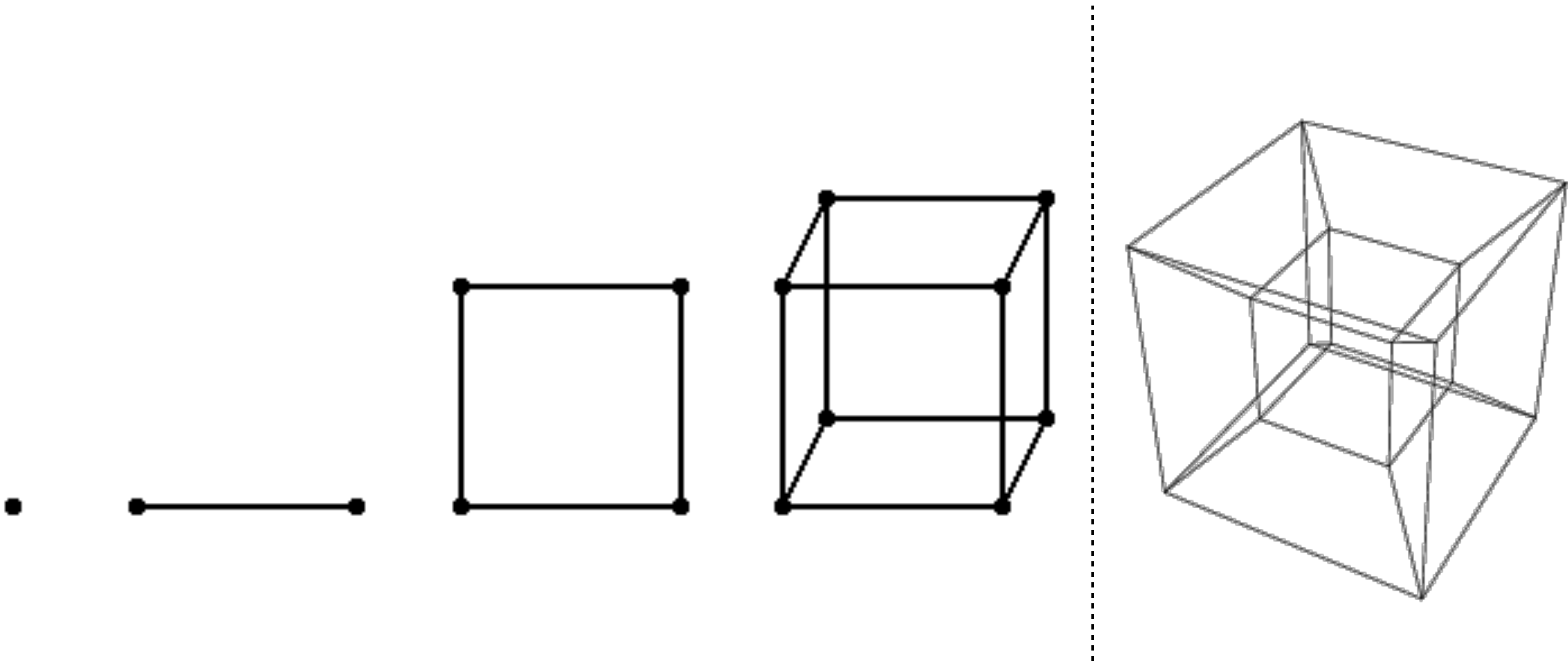

Hypercube

Wir sind eine Tankstelle





Was ist die Tankstelle der Zukunft?

1. Zukunftsfrage

Von: Wie sieht DIE Tankstelle
der Zukunft aus?

Zu: Wer sind UNSERE
Kunden, in Zukunft?

2. Was ist heute, was wird Morgen sein?

heute

morgen

Exponentiell

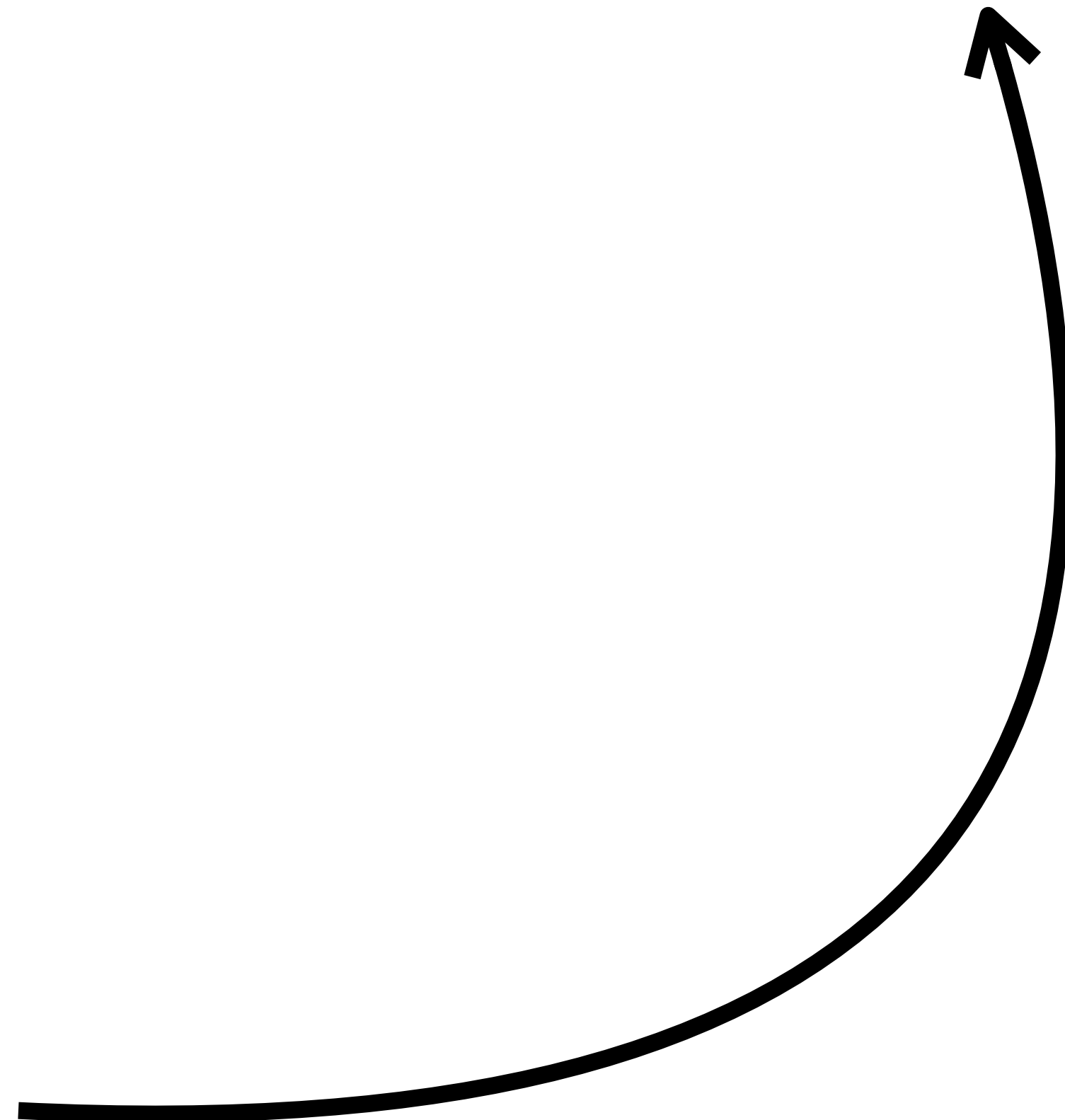

Linear



Ende



2. Open-Mind-Dialog

Thesen zur Zukunft.

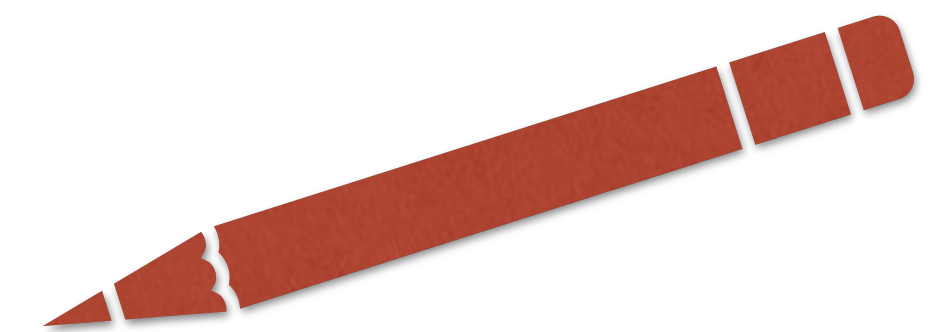



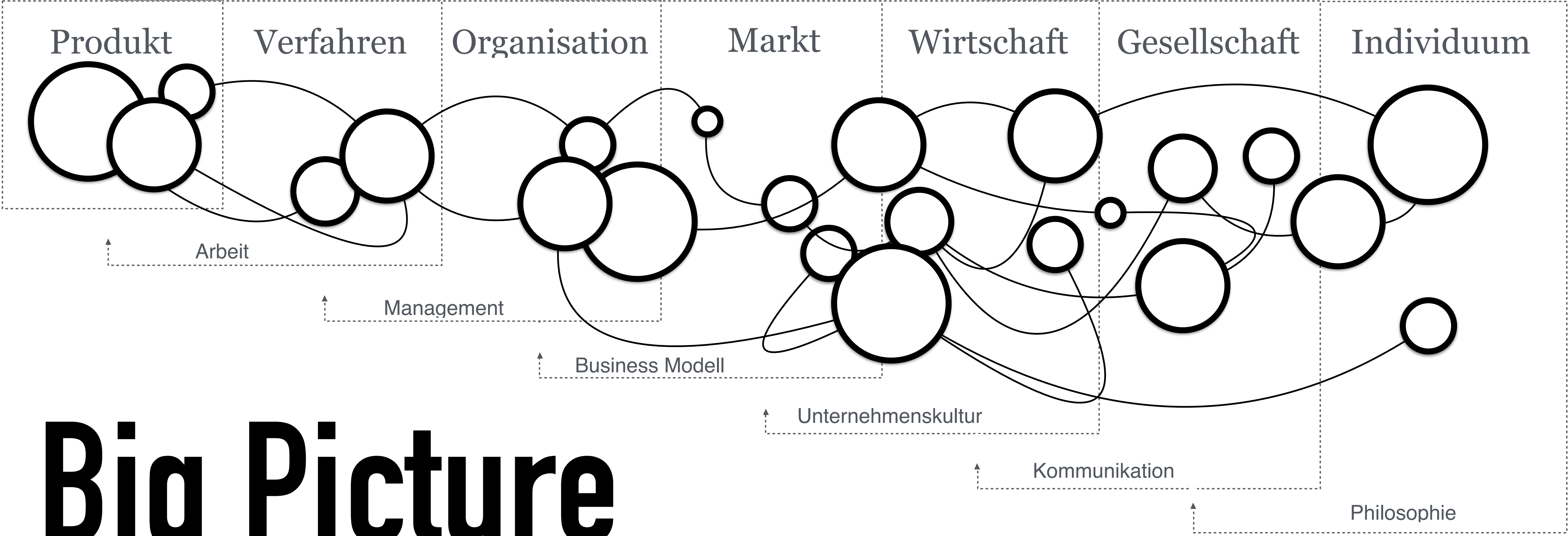

Future-Mindset ihres Unternehmens

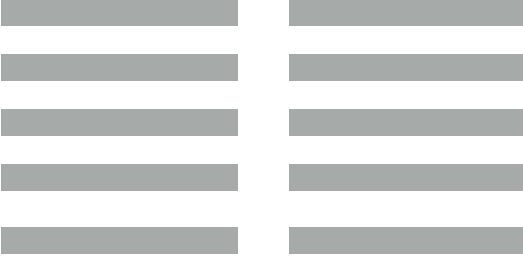
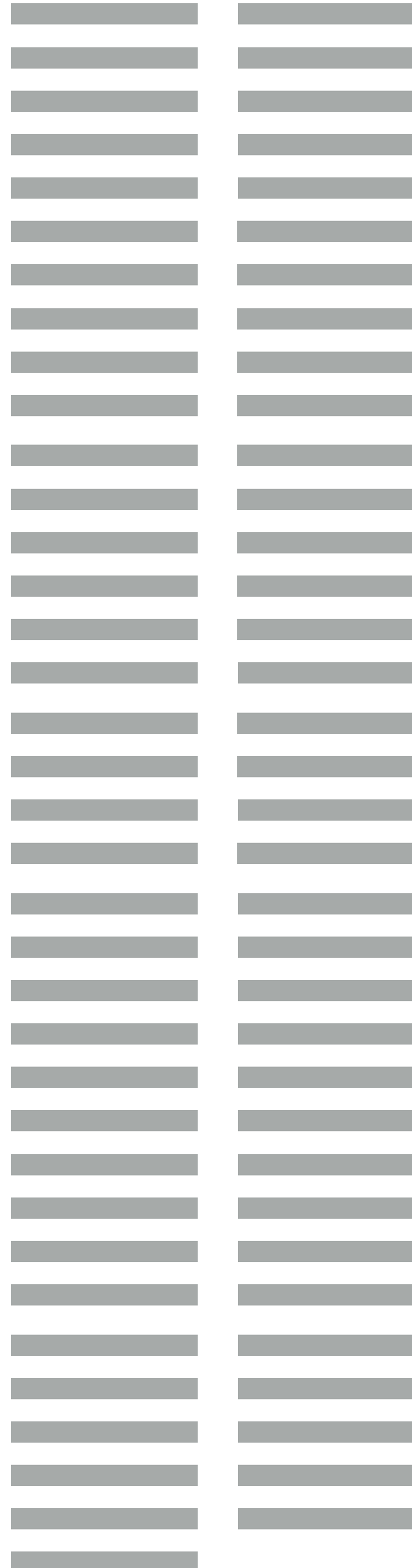

Big Picture

Modell: Form of the Firm, Dirk Baecker / Zukunftsinstitut

PRODUKT	VERFAHREN	ORGANISATION	MARKT	WIRTSCHAFT	GESELLSCHAFT	MENSCH
						

Big Picture

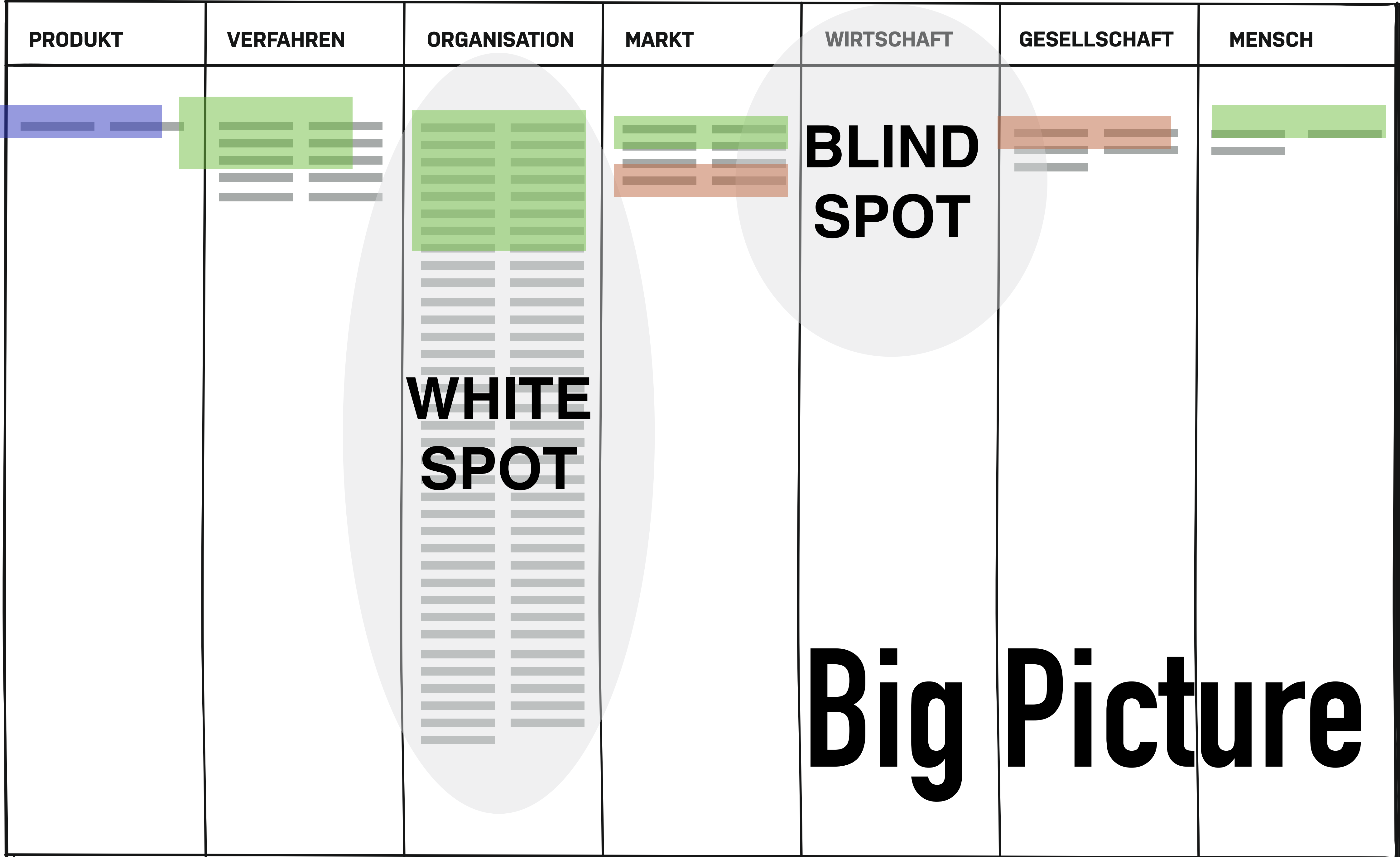

KONSEQUENZEN

für die Zukunft.

Wir bleiben in der Mobilitäts-Branche.

Im „Future Team“ sind nicht nur GF's.

Wir haben ein Budget fürs Denken, und lassen neue Denkgewohnheiten zu.

Wir erstellen UNSERE Hypothesen und etablieren neue Feedback-Schleifen.



Buch

www.zukunftsinstitut.de

und im Handel

Training

10. April 2018 | Wien

www.zukunftsinstitut.de